

Techni-flow[®] 800

332527E

Air-Operated Diaphragm Pumps

EN

2-Inch (51 mm) AODD pump for fluid transfer applications. For professional use only.



Important Safety Instructions

Read all warnings and instructions in this manual. Save these instructions.

120 psi (0.8 MPa, 8 bar) Maximum Fluid Working Pressure
120 psi (0.8 MPa, 8 bar) Maximum Air Input Pressure

Model TF24T072

Aluminum BSPT Pump

Model TF24T073

Aluminum BSPT Pump

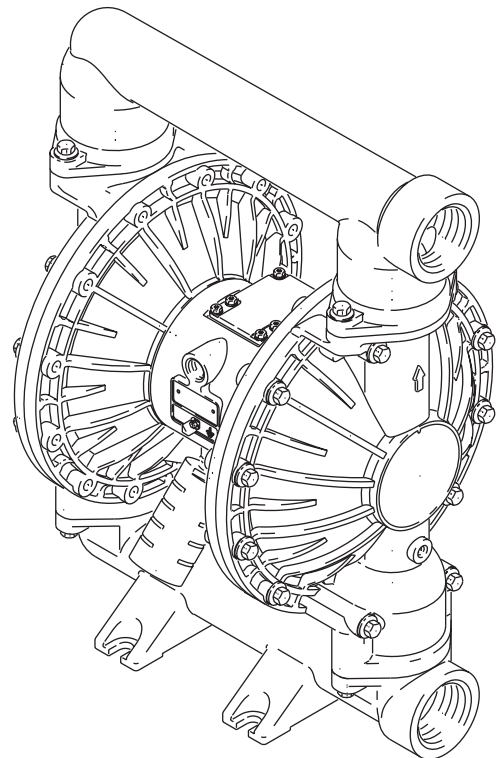

03940B

Contents

Warnings	3	Maintenance	12
Installation	5	Lubrication	12
General Information	5	Flushing and Storage	12
Tightening Threaded Fasteners Before First Use	5	Tightening Threaded Connections	12
Mounting	5	Preventive Maintenance Schedule	12
Grounding	6	Troubleshooting	13
Air Line	7	Service	15
Fluid Suction Line	7	Air Valve	15
Fluid Outlet Line	8	Ball Check Valve Repair	17
Changing the Orientation of the Fluid Inlet and		Diaphragm Repair	18
Outlet Ports	9	Bearing and Air Gasket Removal	21
Fluid Pressure Relief Valve	9	Torque Sequence	23
Air Exhaust Ventilation	10	Parts	24
Operation	11	Common Parts - All Pumps	25
Pressure Relief Procedure	11	Fluid Section Repair Kits	25
Flush Before Using Equipment	11	Dimensions	27
Starting and Adjusting the Pump	11	Performance Charts	28
Pump Shutdown	11	Technical Data	29
		Techni-flow Standard Warranty	30

Models

Sample Configuration Number

TFG800	A	SP
Pump Model	Fluid Covers and Manifolds	Diaphragms



Pump Model	Fluid Section	Diaphragms
2 in. (51 mm) bspt ports, 568 l/min.	Aluminum A	Santoprene SP
		PTFE TF

Your Part Number and Configuration Number are marked on the pump's serial plate. The listing of existing Techni-flow 800 pumps is below.

Part Number	Configuration Number	Components			
		Fluid Section	Guides	Balls	Diaphragms
TF24T072	TFG800ASP	Aluminum	Santoprene	Santoprene	Santoprene
TF24T073	TFG800ATF	Aluminum	Polypropylene	PTFE	PTFE



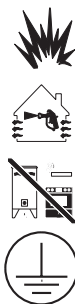



Warnings

The following warnings are for the setup, use, grounding, maintenance, and repair of this equipment. The exclamation point symbol alerts you to a general warning and the hazard symbols refer to procedure-specific risks. When these symbols appear in the body of this manual or on warning labels, refer back to these Warnings. Product-specific hazard symbols and warnings not covered in this section may appear throughout the body of this manual where applicable.

 WARNING	
	<p>FIRE AND EXPLOSION HAZARD</p> <p>Flammable fumes, such as solvent and paint fumes, in work area can ignite or explode. To help prevent fire and explosion:</p> <ul style="list-style-type: none"> • Use equipment only in well ventilated area. • Eliminate all ignition sources; such as pilot lights, cigarettes, portable electric lamps, and plastic drop cloths (potential static arc). • Keep work area free of debris, including solvent, rags and gasoline. • Do not plug or unplug power cords, or turn power or light switches on or off when flammable fumes are present. • Ground all equipment in the work area. See Grounding instructions. • Use only grounded hoses. • Hold gun firmly to side of grounded pail when triggering into pail. Do not use pail liners unless they are antistatic or conductive. • Stop operation immediately if static sparking occurs or you feel a shock. Do not use equipment until you identify and correct the problem. • Keep a working fire extinguisher in the work area. • Route exhaust away from all ignition sources. If diaphragm ruptures, fluid may be exhausted with air.
	<p>PRESSURIZED EQUIPMENT HAZARD</p> <p>Fluid from the equipment, leaks, or ruptured components can splash in the eyes or on skin and cause serious injury.</p> <ul style="list-style-type: none"> • Follow the Pressure Relief Procedure when you stop spraying/dispensing and before cleaning, checking, or servicing equipment. • Tighten all fluid connections before operating the equipment. • Check hoses, tubes, and couplings daily. Replace worn or damaged parts immediately.





WARNING

 	<p>EQUIPMENT MISUSE HAZARD</p> <p>Misuse can cause death or serious injury.</p> <ul style="list-style-type: none"> • Do not operate the unit when fatigued or under the influence of drugs or alcohol. • Do not exceed the maximum working pressure or temperature rating of the lowest rated system component. See Technical Data in all equipment manuals. • Use fluids and solvents that are compatible with equipment wetted parts. See Technical Data in all equipment manuals. Read fluid and solvent manufacturer's warnings. For complete information about your material, request MSDS from distributor or retailer. • Do not leave the work area while equipment is energized or under pressure. • Turn off all equipment and follow the Pressure Relief Procedure when equipment is not in use. • Check equipment daily. Repair or replace worn or damaged parts immediately with genuine manufacturer's replacement parts only. • Do not alter or modify equipment. Alterations or modifications may void agency approvals and create safety hazards. • Make sure all equipment is rated and approved for the environment in which you are using it. • Use equipment only for its intended purpose. Call your distributor for information. • Route hoses and cables away from traffic areas, sharp edges, moving parts, and hot surfaces. • Do not kink or over bend hoses or use hoses to pull equipment. • Keep children and animals away from work area. • Comply with all applicable safety regulations.
 	<p>TOXIC FLUID OR FUMES HAZARD</p> <p>Toxic fluids or fumes can cause serious injury or death if splashed in the eyes or on skin, inhaled, or swallowed.</p> <ul style="list-style-type: none"> • Read MSDSs to know the specific hazards of the fluids you are using. • Route exhaust away from work area. If diaphragm ruptures, fluid may be exhausted into the air. • Store hazardous fluid in approved containers, and dispose of it according to applicable guidelines.
	<p>PRESSURIZED ALUMINUM PARTS HAZARD</p> <p>Use of fluids that are incompatible with aluminum in pressurized equipment can cause serious chemical reaction and equipment rupture. Failure to follow this warning can result in death, serious injury, or property damage.</p> <ul style="list-style-type: none"> • Do not use 1,1,1-trichloroethane, methylene chloride, other halogenated hydrocarbon solvents or fluids containing such solvents. • Many other fluids may contain chemicals that can react with aluminum. Contact your material supplier for compatibility.
	<p>PERSONAL PROTECTIVE EQUIPMENT</p> <p>Wear appropriate protective equipment when in the work area to help prevent serious injury, including eye injury, hearing loss, inhalation of toxic fumes, and burns. This protective equipment includes but is not limited to:</p> <ul style="list-style-type: none"> • Protective eyewear, and hearing protection. • Respirators, protective clothing, and gloves as recommended by the fluid and solvent manufacturer

Installation

General Information

- The Typical Installation in FIG. 2 is only a guide for selecting and installing system components. Contact your Techni-flow representative for assistance in planning a system to suit your needs.
- Reference numbers and letters in parentheses refer to the callouts in the figures and the Parts lists.





						
<p>To reduce the risk of serious injury, splashing in the eyes or on the skin, and toxic fluid spills, never move or lift a pump under pressure. If dropped, the fluid section may rupture. Always follow the Pressure Relief Procedure on page 11 before moving or lifting the pump.</p>						

- The pump is very heavy. If it must be moved, have two people lift the pump by grasping the outlet manifold (103) securely. See FIG. 3 on page 9.

Tightening Threaded Fasteners Before First Use



Before using the pump for the first time, check and retorque all external fasteners. See **Torque Sequence**, page 23. After the first day of operation, retorque the fasteners. Although pump use varies, a general guideline is to retorque fasteners every two months.

Mounting

						
<p>Be sure the system is properly ventilated for your type of installation. You must vent the exhaust to a safe place, away from people, animals, food handling areas, and all sources of ignition when pumping flammable or hazardous fluids.</p> <p>Diaphragm failure will cause the fluid being pumped to exhaust with the air. Place an appropriate container at the end of the air exhaust line to catch the fluid.</p>						

- Be sure the mounting surface can support the weight of the pump, hoses, and accessories, as well as the stress caused during operation.
- For all mountings, be sure the pump is bolted directly to the mounting surface.
- For ease of operation and service, mount the pump so the air valve cover (2), air inlet, and fluid inlet and outlet ports are easily accessible.
- Rubber Foot Mounting Kit 236452 is available to reduce noise and vibration during operation.

Grounding

						
---	---	---	--	--	--	--

To reduce the risk of static sparking, ground the pump and all other equipment used or located in the pumping area. Static sparking can cause fumes to ignite or explode. Grounding provides an escape wire for the electric current.

- Check your local electrical code for detailed grounding instructions for your area and type of equipment.

Pump: Connect a ground wire and clamp as show in FIG. 1. Loosen the grounding screw (W). Insert one end of a 12 ga (1.5 mm@) minimum ground wire (Y) behind the grounding screw and tighten the screw securely. Connect the clamp end of the ground wire to a true earth ground. Order Part No. 222011 Ground Wire and Clamp.

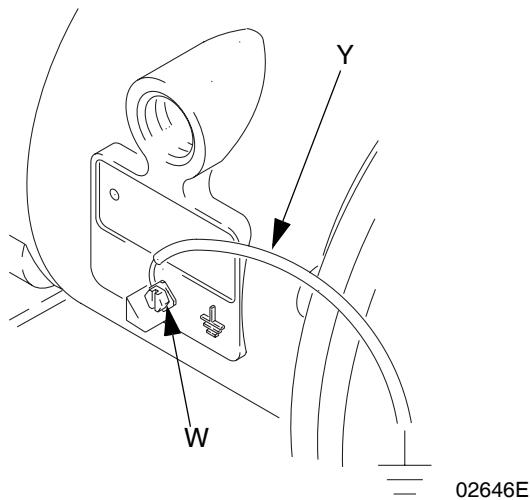

FIG. 1

Air and fluid hoses: use only electrically conductive hoses with a maximum of 500 ft. (150 m) combined hose length to ensure grounding continuity. Check electrical resistance of hoses. If total resistance to ground exceeds 29 megohms, replace hose immediately.

Air compressor: follow manufacturer's recommendations.

Spray gun / Dispense valve: ground through connection to a properly grounded fluid hose and pump.



Fluid supply container: follow local code.



Object being sprayed: follow local code.

Solvent pails used when flushing: follow local code. Use only conductive metal pails, placed on a grounded surface. Do not place the pail on a nonconductive surface, such as paper or cardboard, which interrupts grounding continuity.

To maintain grounding continuity when flushing or relieving pressure: hold metal part of the spray gun/dispense valve firmly to the side of a grounded metal pail, then trigger the gun/valve

Air Line

						
<p>A bleed-type master air valve (B) is required in your system to relieve air trapped between this valve and the pump. See FIG. 2. Trapped air can cause the pump to cycle unexpectedly, which could result in serious injury, including splashing in the eyes or on the skin, injury from moving parts, or contamination from hazardous fluids.</p>						

						
<p>The pump exhaust air may contain contaminants. Ventilate to a remote area. Read Air Exhaust Ventilation, page 10.</p>						

1. Install the air line accessories as shown in FIG. 2. Mount these accessories on the wall or on a bracket. Be sure the air line supplying the accessories is grounded.
 - a. Install an air regulator (C) and gauge to control the fluid pressure. The fluid outlet pressure will be the same as the setting of the air regulator.
 - b. Locate one bleed-type master air valve (B) close to the pump and use it to relieve trapped air. Read the **WARNING** above. Locate the other master air valve (E) upstream from all air line accessories and use it to isolate them during cleaning and repair.
 - c. The air line filter (F) removes harmful dirt and moisture from the compressed air supply.
2. Install an electrically conductive, flexible air hose (A) between the accessories and the 1/2 npt(f) pump air inlet (N). Use a minimum 1/2 in. (13 mm) ID air hose. Screw an air line quick disconnect coupler (D) onto the end of the air hose (A), and screw the mating fitting into the pump air inlet snugly. Do not connect the coupler (D) to the fitting until you are ready to operate the pump.

Fluid Suction Line

- **Use grounded fluid hoses (G).** The pump fluid inlet port (R) is 2 in. (51 mm) bspt. Screw the fluid fitting into the pump inlet securely.
- If the fluid inlet pressure to the pump is more than 25% of the outlet working pressure, the ball check valves will not close fast enough, resulting in inefficient pump operation.
- At inlet fluid pressures greater than 15 psi (0.1 MPa, 1 bar), diaphragm life will be shortened.
- See the **Technical Data**, page 29, for maximum suction lift (wet and dry).

Fluid Outlet Line



A fluid drain valve (J) is required to relieve pressure in the hose if it is plugged. See FIG. 2. The drain valve reduces the risk of serious injury, including splashing in the eyes or on the skin, or contamination from hazardous fluids when relieving pressure. Install the valve close to the pump fluid outlet.

1. Use grounded fluid hoses (L). The pump fluid outlet (S) is 2 in. (51 mm) bspt. Screw the fluid fitting into the pump outlet securely.
2. Install a fluid drain valve (J) near the fluid outlet. Read the **WARNING** above.
3. Install a shutoff valve (K) in the fluid outlet line.

Key:

- A Air supply hose
- B Bleed-type master air valve (required for pump)
- C Air regulator
- D Air line quick disconnect
- E Master air valve (for accessories)
- F Air line filter
- G Fluid suction hose
- H Fluid supply
- J Fluid drain valve (required)
- K Fluid shutoff valve
- L Fluid hose
- M 1/2 npt(f) air inlet port
- N 2 bspt fluid inlet port
- P 2 bspt fluid outlet port
- Q Ground wire (required, see page 6 for installation instructions)

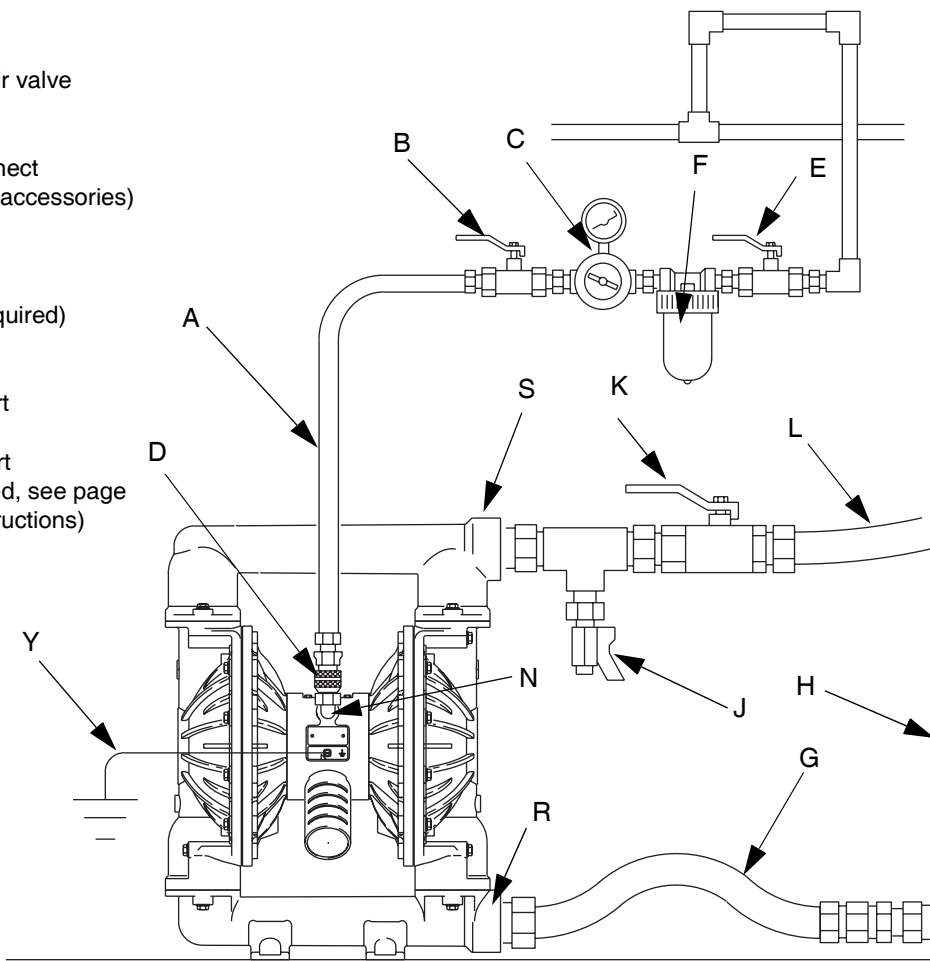

03943B

FIG. 2, Floor-mount typical installation.

Changing the Orientation of the Fluid Inlet and Outlet Ports

The pump is shipped with the fluid inlet (R) and outlet (S) ports facing the same direction. See FIG. 3. To change the orientation of the inlet and/or outlet port:

1. Follow the **Pressure Relief Procedure**, page 11.
2. Remove the screws (106) holding the inlet (102) and/or outlet (103) manifold to the covers (101).
3. Reverse the manifold and reattach. Install the screws and torque to 120 to 150 in-lb (14 to 17 N•m). See **Torque Sequence**, page 23.

Key:

- N 1/2 npt(f) air inlet port
- P Muffler - air exhaust port is 3/4 npt(f)
- R 2 in. (51 mm) bspt fluid inlet port
- S 2 in. (51 mm) bspt fluid outlet port
- 101 Covers
- 102 Fluid inlet manifold
- 103 Fluid outlet manifold
- 106 Manifold and cover screws
- 112 Cover screws (top and bottom)

- ▲1 Apply medium-strength (blue) thread locker to the threads. Torque to 120 to 150 in-lb (14 to 17 N•m). See **Torque Sequence**, page 23.
- ▲2 Apply medium-strength (blue) thread locker to the threads. Torque to 190 to 220 in-lb (22 to 25 N•m). See **Torque Sequence**, page 23

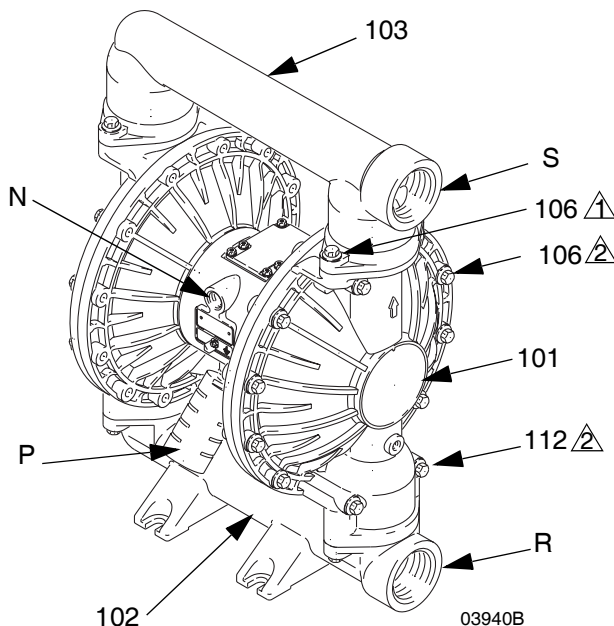

FIG. 3

Fluid Pressure Relief Valve



Some systems may require installation of a pressure relief valve at the pump outlet to prevent overpressurization and rupture of the pump or hose. See FIG. 4.

Thermal expansion of fluid in the outlet line can cause overpressurization. This can occur when using long fluid lines exposed to sunlight or ambient heat, or when pumping from a cool to a warm area (for example, from an underground tank).

Overpressurization can also occur if the pump is being used to feed fluid to a piston pump, and the intake valve of the piston pump does not close, causing fluid to back up in the outlet line.

Key:

- R 2 in. (51 mm) bspt fluid inlet port
- S 2 in. (51 mm) bspt fluid outlet port
- V Pressure relief valve, Part No. 112119 (stainless steel)

- ▲1 Install valve between fluid inlet and outlet ports.
- ▲2 Connect fluid inlet line here.
- ▲3 Connect fluid outlet line here.

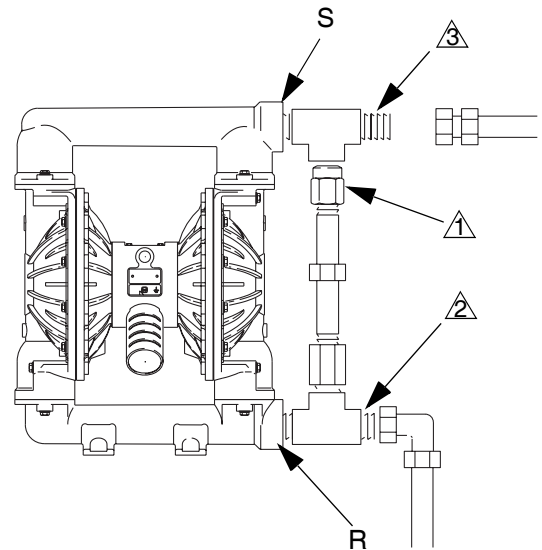

FIG. 4

Air Exhaust Ventilation



Be sure the system is properly ventilated for your type of installation. You must vent the exhaust to a safe place, away from people, animals, food handling areas, and all sources of ignition when pumping flammable or hazardous fluids.

Diaphragm failure will cause the fluid being pumped to exhaust with the air. Place an appropriate container at the end of the air exhaust line to catch the fluid. See FIG. 5.

The air exhaust port is 3/4 npt(f). Do not restrict the air exhaust port. Excessive exhaust restriction can cause erratic pump operation.

If the muffler (P) is installed directly to the air exhaust port, apply PTFE thread tape or anti-seize thread lubricant to the muffler threads before assembly.

Exhaust to a remote location as follows:

1. Remove the muffler (P) from the pump air exhaust port.
2. Install a grounded air exhaust hose (T) and connect the muffler to the other end of the hose. The minimum size for the air exhaust hose is 3/4 in. (19 mm) ID. If a hose longer than 15 ft (4.57 m) is required, use a larger diameter hose. Avoid sharp bends or kinks in the hose.
3. Place a container (U) at the end of the air exhaust line to catch fluid in case a diaphragm ruptures.

Key:

- A Air supply line
- B Bleed-type master air valve (required for pump)
- C Air regulator
- D Air line quick disconnect
- E Master air valve (for accessories)
- F Air line filter
- P Muffler
- T Grounded air exhaust hose
- U Container for remote air exhaust

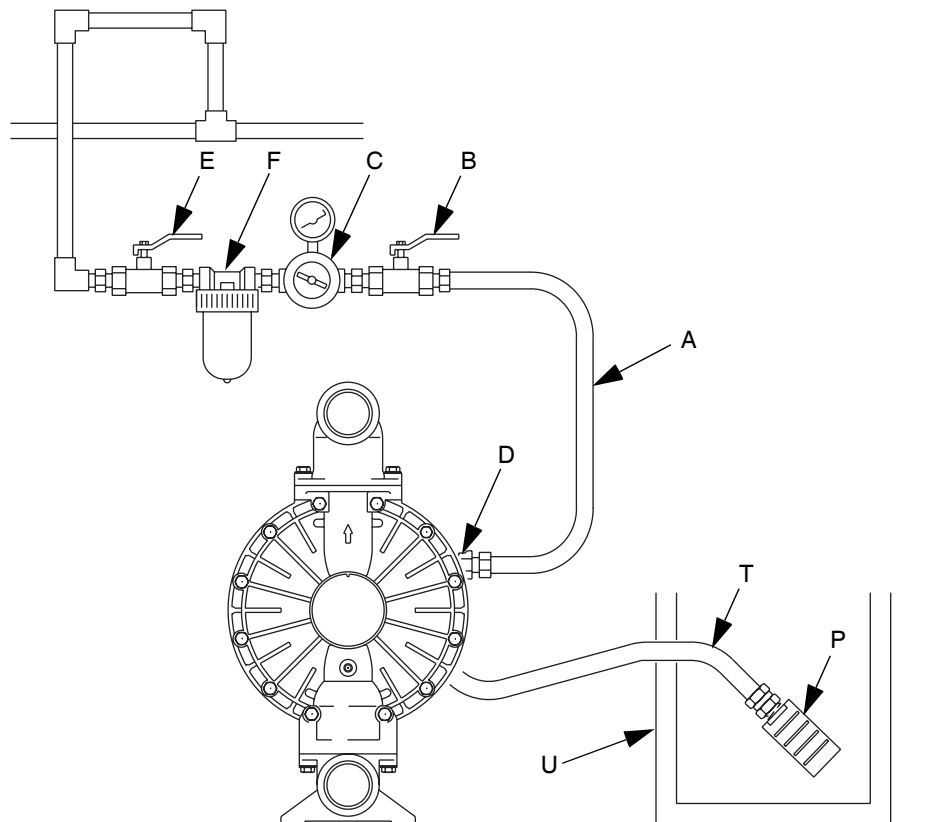

03942

FIG. 5, Venting Exhaust Air

Operation

Pressure Relief Procedure



Follow the **Pressure Relief Procedure** whenever you see this symbol.



This equipment stays pressurized until pressure is manually relieved. To help prevent serious injury from pressurized fluid, accidental spray, or splashing fluid, follow the **Pressure Relief Procedure** when you stop spraying and before cleaning, checking, or servicing the equipment.

1. Shut off air to the pump.
2. Open the dispensing valve, if used.
3. Open the fluid drain valve to relieve all fluid pressure, and have a container ready to catch the drainage.

Flush Before Using Equipment

The pump was tested in water. If water could contaminate the fluid you are pumping, flush it thoroughly with a compatible solvent. Follow the steps under **Starting and Adjusting the Pump**.

Starting and Adjusting the Pump



1. Make sure the pump is properly grounded. See **Grounding**, page 6.
2. Check all fittings to be sure they are tight. Use a compatible liquid thread sealant on all male threads. Tighten the fluid inlet and outlet fittings snugly.
3. Place the suction tube (if used) in the fluid to be pumped.

NOTE: If the inlet fluid pressure to the pump is more than 25% of the outlet working pressure, the ball check valves will not close fast enough, resulting in inefficient pump operation.

4. Place the end of the fluid hose (L) into an appropriate container.
5. Close the fluid drain valve (J).
6. With the pump air regulator (C) closed, open all bleed-type master air valves (B, E).
7. If the fluid hose has a dispensing device, hold it open while continuing with the following step. Slowly open the air regulator (G) until the pump starts to cycle. Allow the pump to cycle slowly until all air is pushed out of the lines and the pump is primed.

If you are flushing, run the pump long enough to thoroughly clean the pump and hoses. Close the air regulator. Remove the suction tube from the solvent and place it in the fluid to be pumped.

Pump Shutdown

At the end of the work shift and before checking, adjusting, cleaning or repairing the system, follow the **Pressure Relief Procedure**, page 11.

Maintenance

Lubrication

The air valve is lubricated at the factory to operate without additional lubrication. If you want to provide additional lubrication, remove the hose from the pump air inlet and add two drops of machine oil to the air inlet every 500 hours of operation or every month.

NOTICE

Do not over-lubricate the pump. Oil is exhausted through the muffler, which could contaminate your fluid supply or other equipment. Excessive lubrication can also cause the pump to malfunction.

Flushing and Storage

Flush the pump often enough to prevent the fluid you are pumping from drying or freezing in the pump and damaging it. Use a compatible solvent.

Always flush the pump and follow the **Pressure Relief Procedure**, page 11, before you store it for any length of time.

Tightening Threaded Connections

Before each use, check all hoses for wear or damage and replace as necessary. Check to be sure all threaded connections are tight and leak-free.

Check fasteners. Tighten or retorque as necessary. Although pump use varies, a general guideline is to retorque fasteners every two months. See **Torque Sequence**, page 23.

Preventive Maintenance Schedule

Establish a preventive maintenance schedule, based on the pump's service history. This is especially important for prevention of spills or leakage due to diaphragm failure.

Troubleshooting



1. Follow **Pressure Relief Procedure**, page 11, before checking or repairing the pump.
2. Check all possible problems and causes before disassembling the pump.

Problem	Cause	Solution
Pump cycles at stall or fails to hold pressure at stall.	Worn check valve balls (301), seats (201) or o-rings (202).	Replace. See page 17.
Pump will not cycle, or cycles once and stops.	Air valve is stuck or dirty.	Disassemble and clean air valve. See page 15. Use filtered air.
	Check valve ball (301) severely worn and wedged in seat (201) or manifold (102 or 103).	Replace ball and seat. See page 17.
	Check valve ball (301) is wedged into seat (201) due to overpressurization.	Install Pressure Relief Valve (see page 9).
	Dispensing valve clogged.	Relieve pressure and clear valve.
Pump operates erratically.	Clogged suction line.	Inspect; clear.
	Sticky or leaking check valve balls (301).	Clean or replace. See page 17.
	Diaphragm ruptured.	Replace. See page 18.
	Restricted exhaust.	Remove restriction.
Air bubbles in fluid.	Suction line is loose.	Tighten.
	Diaphragm ruptured.	Replace. See page 18.
	Loose inlet manifold (102), damaged seal between manifold and seat (201), or damaged o-rings (202).	Tighten manifold bolts (106) or replace seats (201) or o-rings (202). See page 17.
	Loose diaphragm shaft bolt (107).	Tighten or replace. See page 18.
	Damaged o-ring (108).	Replace. See page 18.
Fluid in exhaust air.	Diaphragm ruptured.	Replace. See page 18.
	Loose diaphragm shaft bolt (107).	Tighten or replace. See page 18.
	Damaged o-ring (108).	Replace. See page 18.
Pump exhausts excessive air at stall.	Worn air valve block (7), o-ring (6), plate (8), pilot block (18), u-cups (10), or pilot pin o-rings (17).	Repair or replace. See page 15.
	Worn shaft seals (402).	Replace. See page 18.

Problem	Cause	Solution
Pump leaks air externally.	Air valve cover (2) or air valve cover screws (3) are loose.	Tighten screws. See page 15.
	Air valve gasket (4) or air cover gasket (22) is damaged.	Inspect and replace. See page 15.
	Air cover screws (3) are loose.	Tighten screws. See page 21.
Pump leaks fluid externally from ball check valves.	Loose manifolds (102, 103), damaged seal between manifold and seat (201), or damaged o-rings (202).	Tighten manifold bolts (106) or replace seats (201) or o-rings (202). See page 17.

Service



Air Valve

Tools Required

- Torque wrench
- Torx (T20) screwdriver or 7 mm (9/32 in) socket wrench
- Needle-nose pliers
- O-ring pick
- Lithium base grease

NOTE: Air Valve Repair Kit 236273 is available. Parts included in the kit are marked with a symbol, for example (4†). Use all the parts in the kit for the best results.

Disassembly

1. Follow the **Pressure Relief Procedure** on page 11.
2. With a Torx (T20) screwdriver or 7 mm (9/32 in) socket wrench, remove the six screws (3), air valve cover (2), and gasket (4). See FIG. 6.
3. Move the valve carriage (5) to the center position and pull it out of the cavity. Remove the valve block (7) and o-ring (6) from the carriage. Using a needle-nose pliers, pull the pilot block (18) straight up and out of the cavity. See FIG. 7.
4. Pull the two actuator pistons (11) out of the bearings (12). Remove the u-cup packings (10) from the pistons. Pull the pilot pins (16) out of the bearings (15). Remove the o-rings (17) from the pilot pins. See FIG. 8.
5. Inspect the valve plate (8) in place. If damaged, use a Torx (T20) screwdriver or 7 mm (9/32 in) socket wrench to remove the three screws (3). Remove the valve plate (8) and seal (9). See FIG. 9.
6. Inspect the bearings (12, 15) in place. See FIG. 8. The bearings are tapered and, if damaged, must be removed from the outside. This requires disassembly of the fluid section. See page 21.
7. Clean all parts and inspect for wear or damage. Replace as needed. Reassemble as explained on page 16.

† Torque to 50 to 60 in-lb (5.6 to 6.8 N•m).

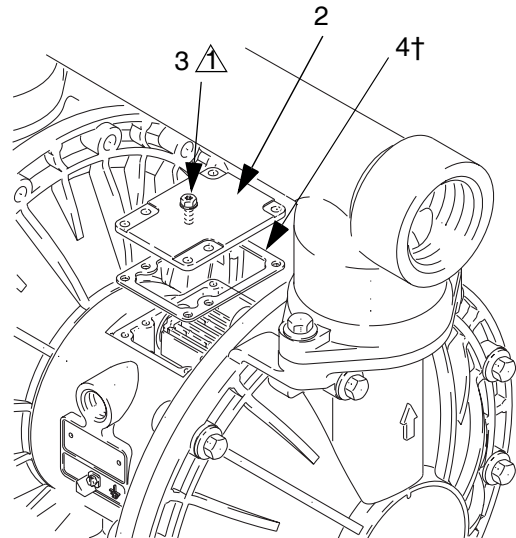

03944

FIG. 6

- † See Detail at right.
- ‡ Grease.
- ‡ Grease lower face.

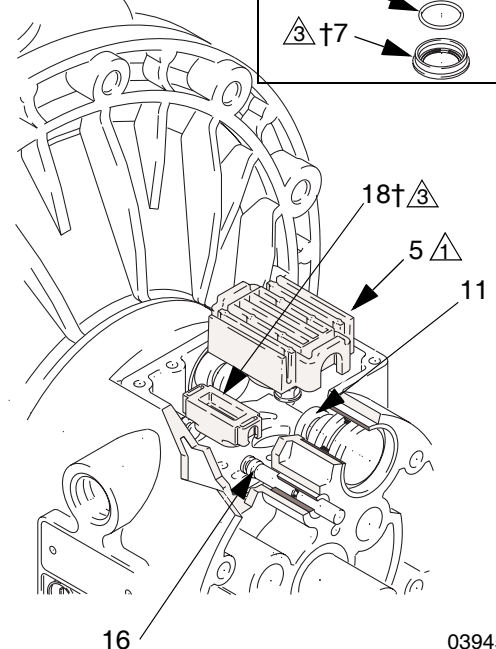
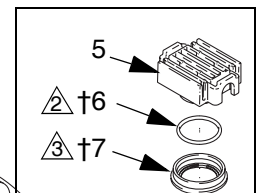

03945

FIG. 7

- ▲ 1 Insert narrow end first.
- ▲ 2 Grease.
- ▲ 3 Install with lips facing narrow end of piston (11).
- ▲ 4 Insert wide end first.

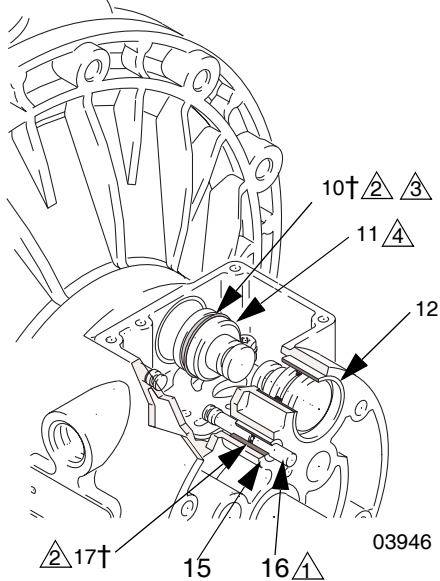

FIG. 8

- ▲ 1 Rounded side must face down.
- ▲ 2 Tighten screws until they bottom out on the housing.

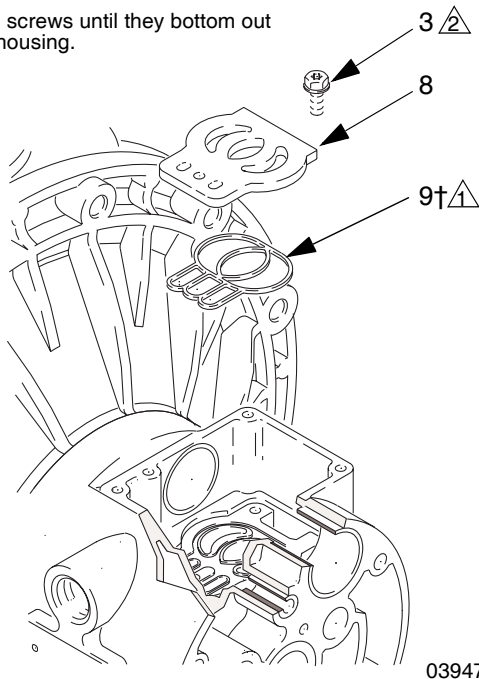

FIG. 9

Reassembly

1. If you removed the bearings (12, 15), install new ones as explained on page 21. Reassemble the fluid section.
2. On aluminum center housing models, install the valve plate seal (9†) into the groove at the bottom of the valve cavity. The rounded side of the seal **must face down** into the groove. See FIG. 9.
3. Install the valve plate (8) in the cavity. The plate is reversible, so either side can face up. Install the three screws (3), using a Torx (T20) screwdriver or 7 mm (9/32 in) socket wrench. Tighten until the screws bottom out on the housing. See FIG. 9.
4. Install an o-ring (17†) on each pilot pin (16). Grease the pins and o-rings. Insert the pins into the bearings (15), **narrow** end first. See FIG. 8.
5. Install a u-cup packing (10†) on each actuator piston (11), so the lips of the packings face the **narrow** end of the pistons. See FIG. 8.
6. Lubricate the u-cup packings (10†) and actuator pistons (11). Insert the actuator pistons in the bearings (12), **wide** end first. Leave the narrow end of the pistons exposed. See FIG. 8.
7. Grease the lower face of the pilot block (18†) and install so its tabs snap into the grooves on the ends of the pilot pins (16). See FIG. 7.
8. Grease the o-ring (6†) and install it in the valve block (7†). Push the block onto the valve carriage (5). Grease the lower face of the valve block. See FIG. 7.
9. Install the valve carriage (5) so its tabs slip into the grooves on the narrow end of the actuator pistons (11). See FIG. 7.
10. Align the valve gasket (4†) and cover (2) with the six holes in the center housing (1). Secure with six screws (3), using a Torx (T20) screwdriver or 7 mm (9/32 in) socket wrench. Torque to 50 to 60 in-lb (5.6 to 6.8 N•m). See FIG. 6.

Ball Check Valve Repair

Tools Required

- Torque wrench
- 10 mm socket wrench
- O-ring pick

Disassembly

NOTE: A Fluid Section Repair Kit is available. Refer to page 25 to order the correct kit for your pump. Parts included in the kit are marked with an asterisk, for example (201*). Use all the parts in the kit for the best results.

NOTE: To ensure proper seating of the balls (301), always replace the seats (201) when replacing the balls.

1. Follow the **Pressure Relief Procedure** on page 11. Disconnect all hoses.
2. Remove the pump from its mounting.
3. Using a 10 mm socket wrench, remove the four bolts (106) holding the outlet manifold (103) to the fluid covers (101). See FIG. 10.
4. Remove the seats (201), balls (301), and o-rings (202) from the manifold.
5. Turn the pump over and remove the inlet manifold (102). Remove the seats (201), balls (301), and o-rings (202) from the fluid covers (101).

Reassembly

1. Clean all parts and inspect for wear or damage. Replace parts as needed.
2. Reassemble in the reverse order, following all notes in FIG. 10. Be sure the ball checks are assembled **exactly** as shown. The arrows (A) on the fluid covers (101) **must** point toward the outlet manifold (103).

① Apply medium-strength (blue) thread locker to the threads. Torque to 120 to 150 in-lb (14 to 17 N•m). See **Torque Sequence**, page 23.

② Arrow (A) must point toward outlet manifold (103).

③ Beveled seating surface must face ball (301).

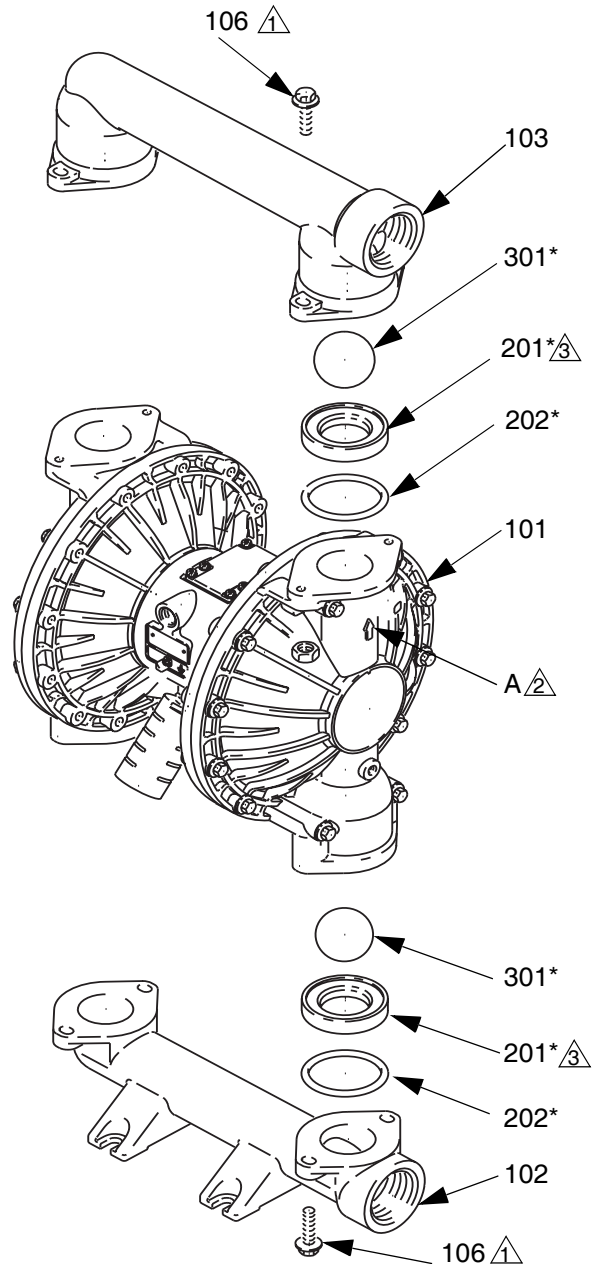

ti0352B

FIG. 10

Diaphragm Repair

Tools Required

- Torque wrench
- 10 mm socket wrench
- 13 mm socket wrench
- 15 mm socket wrench (aluminum models) or
- 19 mm open-end wrench
- O-ring pick
- Lithium-based grease

Disassembly

NOTE: A Fluid Section Repair Kit is available. Refer to page 25 to order the correct kit for your pump. Parts included in the kit are marked with an asterisk, for example (401*). Use all the parts in the kit for the best results.

1. Follow the **Pressure Relief Procedure** on page 11.
2. Remove the manifolds and disassemble the ball check valves as explained on page 17.
3. Using 10 and 13 mm socket wrenches, remove the screws (106 and 112) holding the fluid covers (101) to the air covers (23). Pull the fluid covers (101) off the pump. See FIG. 11.

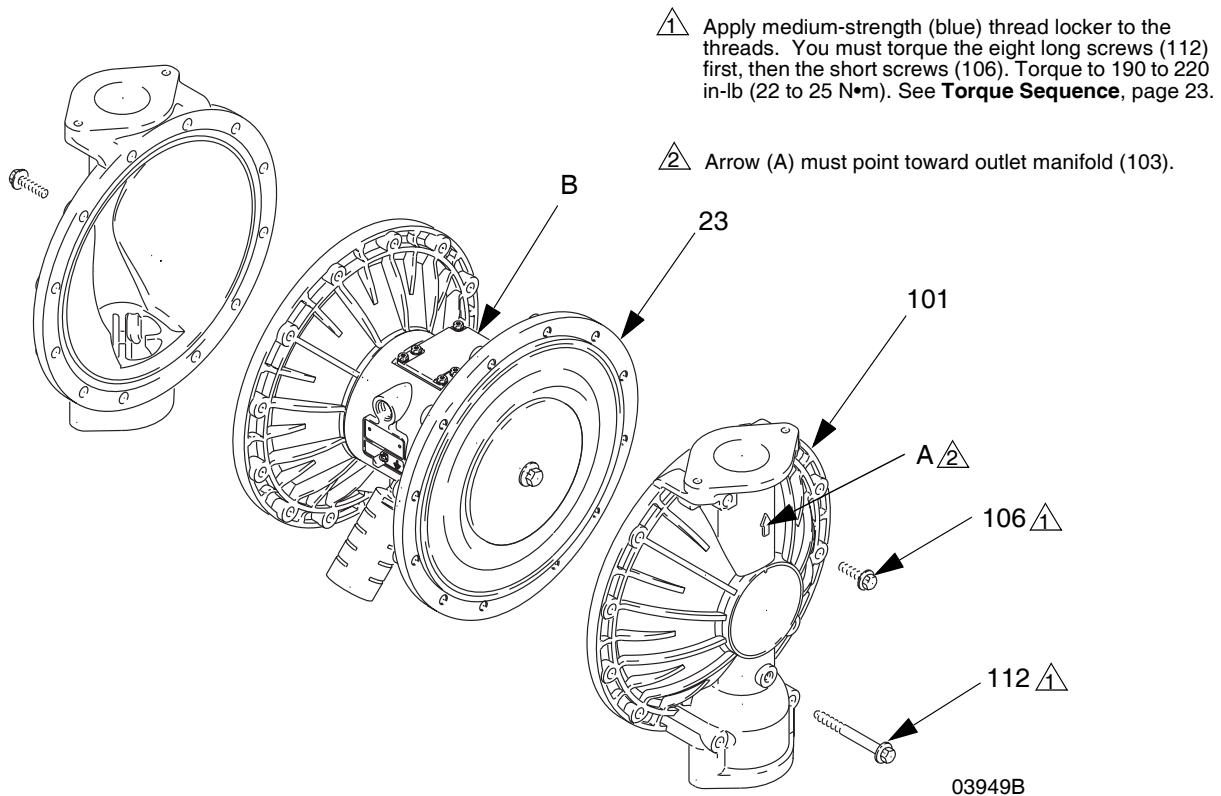
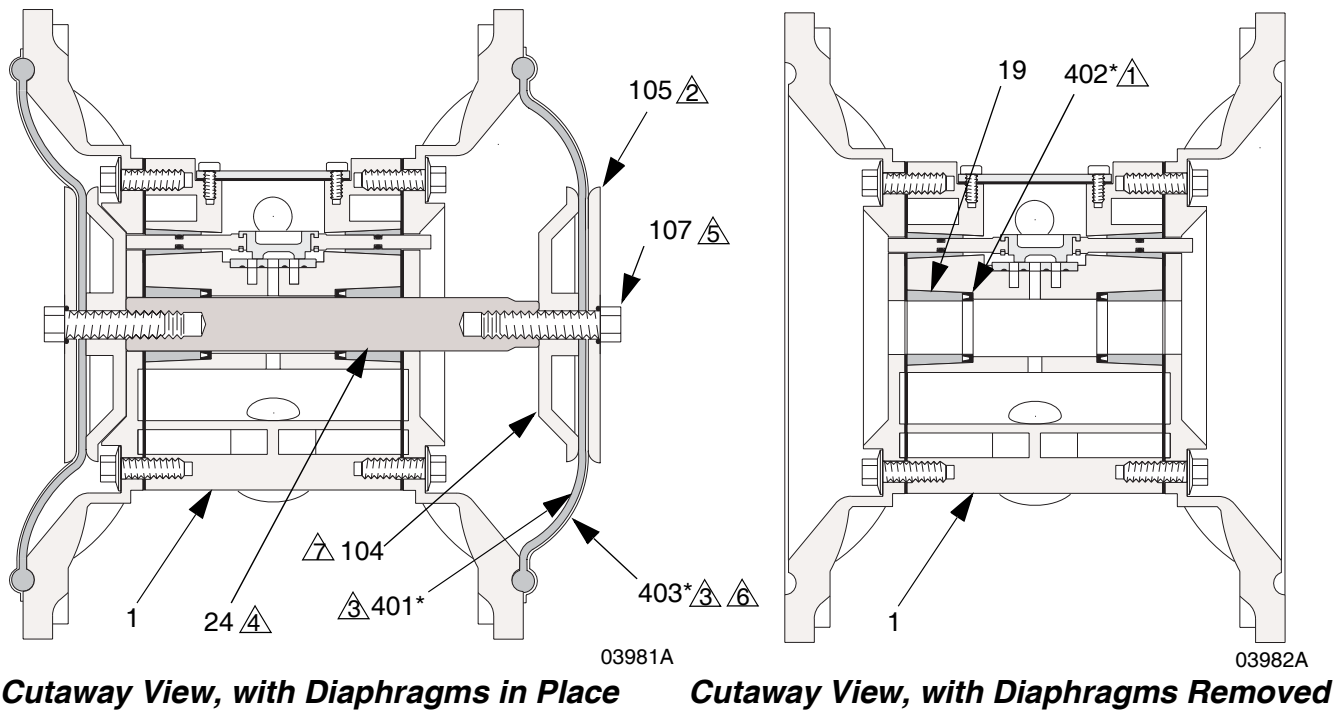

FIG. 11

4. Loosen but do not remove the diaphragm shaft bolts (107), using a 15 mm socket wrench on both bolts.
 5. Unscrew one bolt from the diaphragm shaft (24) and remove the o-ring (108), fluid side diaphragm plate (105), PTFE diaphragm (403, used on PTFE Models only), diaphragm (401), and air side diaphragm plate (104). See FIG. 12.
 6. Pull the other diaphragm assembly and the diaphragm shaft (24) out of the center housing (1). Hold the shaft flats with a 19 mm open-end wrench, and remove the bolt (107) from the shaft. Disassemble the remaining diaphragm assembly.
 7. Inspect the diaphragm shaft (24) for wear or scratches. If it is damaged, inspect the bearings (19) in place. If the bearings are damaged, refer to page 21.
 8. Reach into the center housing (1) with an o-ring pick and hook the u-cup packings (402), then pull them out of the housing. This can be done with the bearings (19) in place.
 9. Clean all parts and inspect for wear or damage. Replace parts as needed.
- f. Apply medium-strength (blue) thread locker to the bolt (107) threads. Screw the bolt into the shaft (24) hand tight.
3. Grease the length and ends of the diaphragm shaft (24), and slide it through the housing (1).
 4. Assemble the other diaphragm assembly to the shaft as explained in step 2.
 5. Hold one shaft bolt (107) with a wrench and torque the other bolt to 20 to 25 ft-lb (27 to 34 N•m) at 100 rpm maximum.
 6. Align the fluid covers (101) and the center housing (1) so the arrows (A) on the covers face the same direction as the air valve (B). Secure the covers with the screws (106 and 112), hand tight. Install the longer screws (112) in the top and bottom holes of the covers. See FIG. 11.
 7. First, torque the longer screws (112) oppositely and evenly to 190 to 220 in-lb (22 to 25 N•m), using a 13 mm socket wrench. Then torque the shorter screws (106), using a 10 mm socket wrench. See 11 **Torque Sequence**, page 23.
 8. Reassemble the ball check valves and manifolds as explained on page 17.

Reassembly

1. Install the shaft u-cup packings (402*) so the lips face **out** of the housing (1). Lubricate the packings. See FIG. 12.
2. Install the diaphragm assembly on one end of the shaft (24) as follows.
 - a. Install the o-ring (108*) on the shaft bolt (107).
 - b. Install the fluid side diaphragm plate (105) on the bolt so the rounded side faces in, toward the diaphragm (401).
 - c. On PTFE Models only, install the PTFE diaphragm (403*). Make certain the side marked AIR SIDE faces the center housing (1).
 - d. Install the diaphragm (401*) on the bolt. Make certain the side marked AIR SIDE faces the center housing (1).
 - e. Install the air side diaphragm plate (104) so the recessed side faces the diaphragm (401).



Cutaway View, with Diaphragms in Place

Cutaway View, with Diaphragms Removed

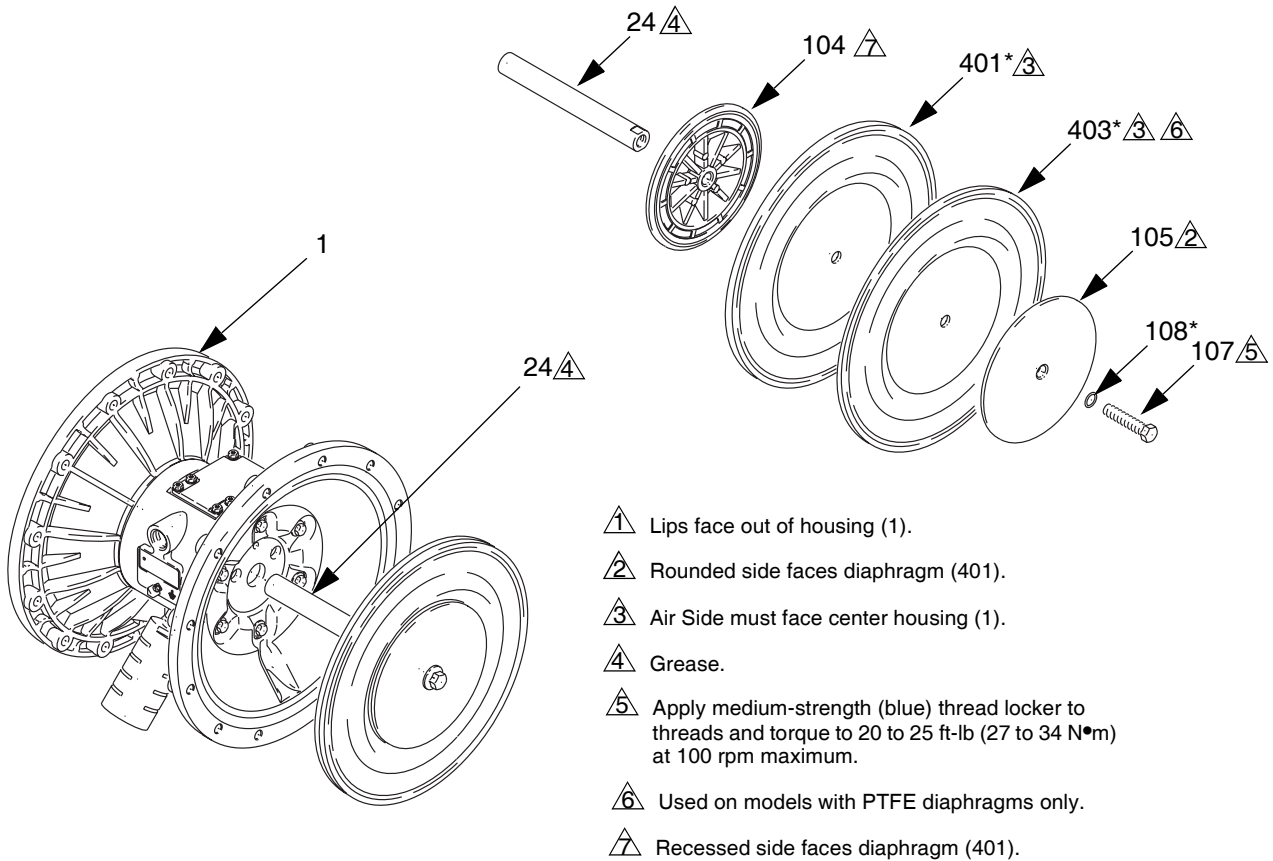

- ① Lips face out of housing (1).
- ② Rounded side faces diaphragm (401).
- ③ Air Side must face center housing (1).
- ④ Grease.
- ⑤ Apply medium-strength (blue) thread locker to threads and torque to 20 to 25 ft-lb (27 to 34 N•m) at 100 rpm maximum.
- ⑥ Used on models with PTFE diaphragms only.
- ⑦ Recessed side faces diaphragm (401).

03950A

FIG. 12, Diaphragms, Polypropylene and PVDF Pumps

Bearing and Air Gasket Removal

Tools Required

- Torque wrench
- 10 mm socket wrench
- Bearing puller
- O-ring pick
- Press, or block and mallet

Disassembly

NOTE: Do not remove undamaged bearings.

1. Follow the **Pressure Relief Procedure** on page 11.
2. Remove the manifolds and disassemble the ball check valves as explained on page 17.
3. Remove the fluid covers and diaphragm assemblies as explained on page 18.



NOTE: If you are removing only the diaphragm shaft bearing (19), skip step 4.

4. Disassemble the air valve as explained on page 15.
5. Using a 10 mm socket wrench, remove the screws (25) holding the air covers (23) to the center housing (1). See FIG. 13.
6. Remove the air cover gaskets (22). Always replace the gaskets with new ones.
7. Use a bearing puller to remove the diaphragm shaft bearings (19), air valve bearings (12) or pilot pin bearings (15). Do not remove undamaged bearings.
8. If you removed the diaphragm shaft bearings (19), reach into the center housing (1) with an o-ring pick and hook the u-cup packings (402), then pull them out of the housing. Inspect the packings. See FIG. 12.

Reassembly

1. If removed, install the shaft u-cup packings (402*) so the lips face **out** of the housing (1).
2. The bearings (19, 12, and 15) are tapered and can only be installed one way. Insert the bearings into the center housing (1), **tapered end first**. Using a press or a block and rubber mallet, press-fit the bearing so it is flush with the surface of the center housing.

3. Reassemble the air valve as explained on page 16.
4. Align the new air cover gasket (22) so the pilot pin (16) protruding from the center housing (1) fits through the proper hole (H) in the gasket.
5. Align the air cover (23) so the pilot pin (16) fits in the middle hole (M) of the three small holes near the center of the cover. Install the screws (25), hand tight. See FIG. 13. Using a 10 mm socket wrench, torque the screws oppositely and evenly to 120 to 150 in-lb (14 to 17 N•m).
6. Install the diaphragm assemblies and fluid covers as explained on page 18.
7. Reassemble the ball check valves and manifolds as explained on page 17.

- 1  Insert bearings tapered end first.
- 2  Press-fit bearings flush with surface of center housing (1).
- 3  Apply medium-strength (blue) thread locker to the threads. Torque to 120 to 150 in-lb (14 to 17 N•m).

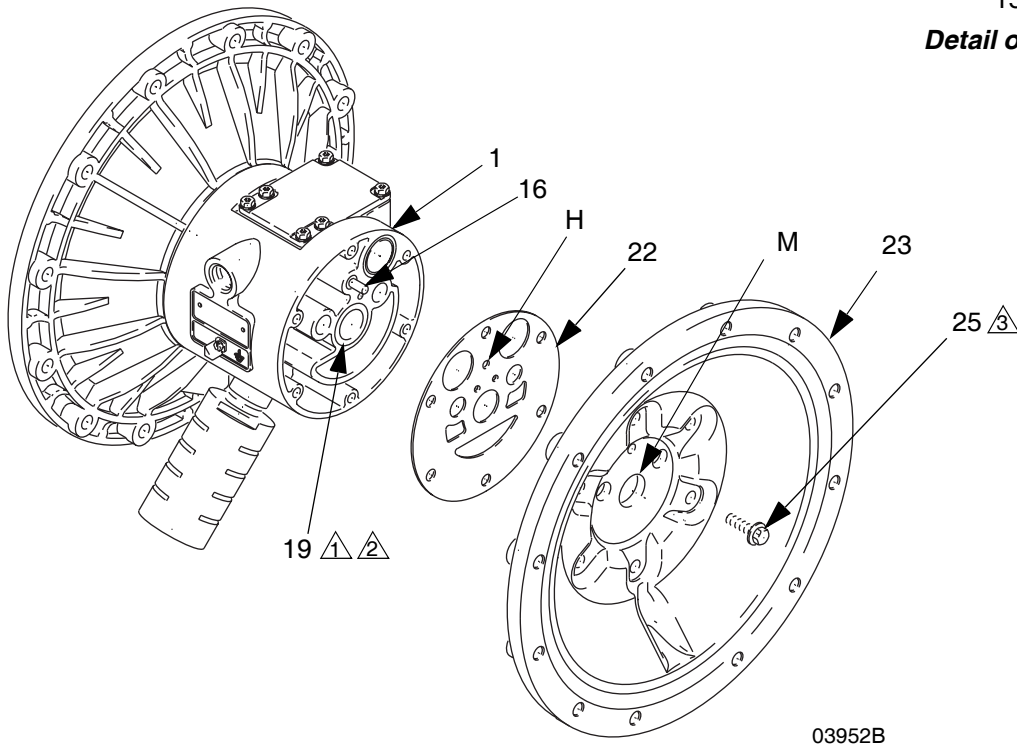
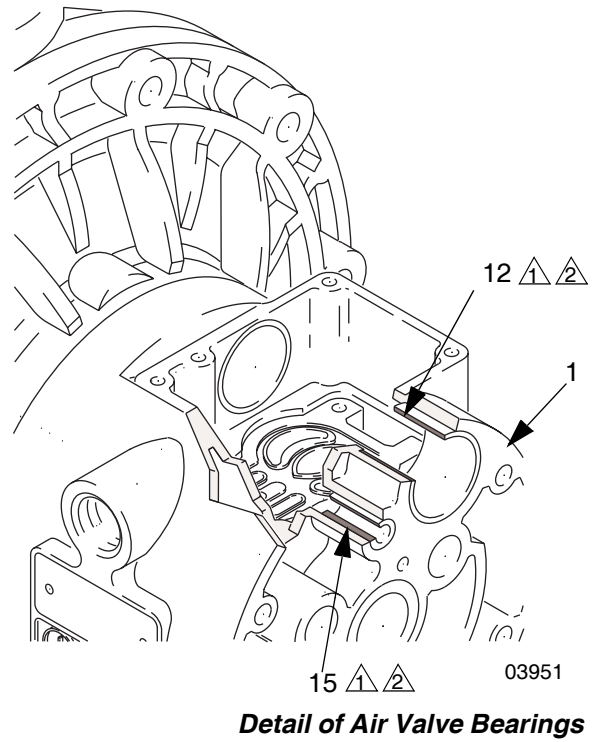
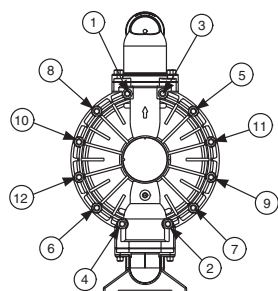

FIG. 13

Torque Sequence

Always follow the torque sequence when instructed to torque fasteners.

1. Left/Right Fluid Covers
Torque bolts to 190 to 220 in-lb (22 to 25 N•m).



Side View

2. Inlet Manifold
Torque bolts to 120 to 150 in-lb (14 to 17 N•m).

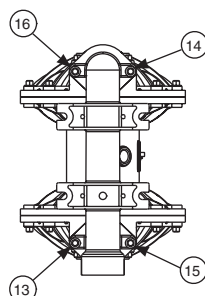

Bottom View

3. Outlet Manifold
Torque bolts to 120 to 150 in-lb (14 to 17 N•m).

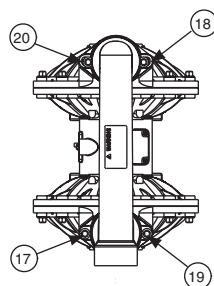

Top View

Parts

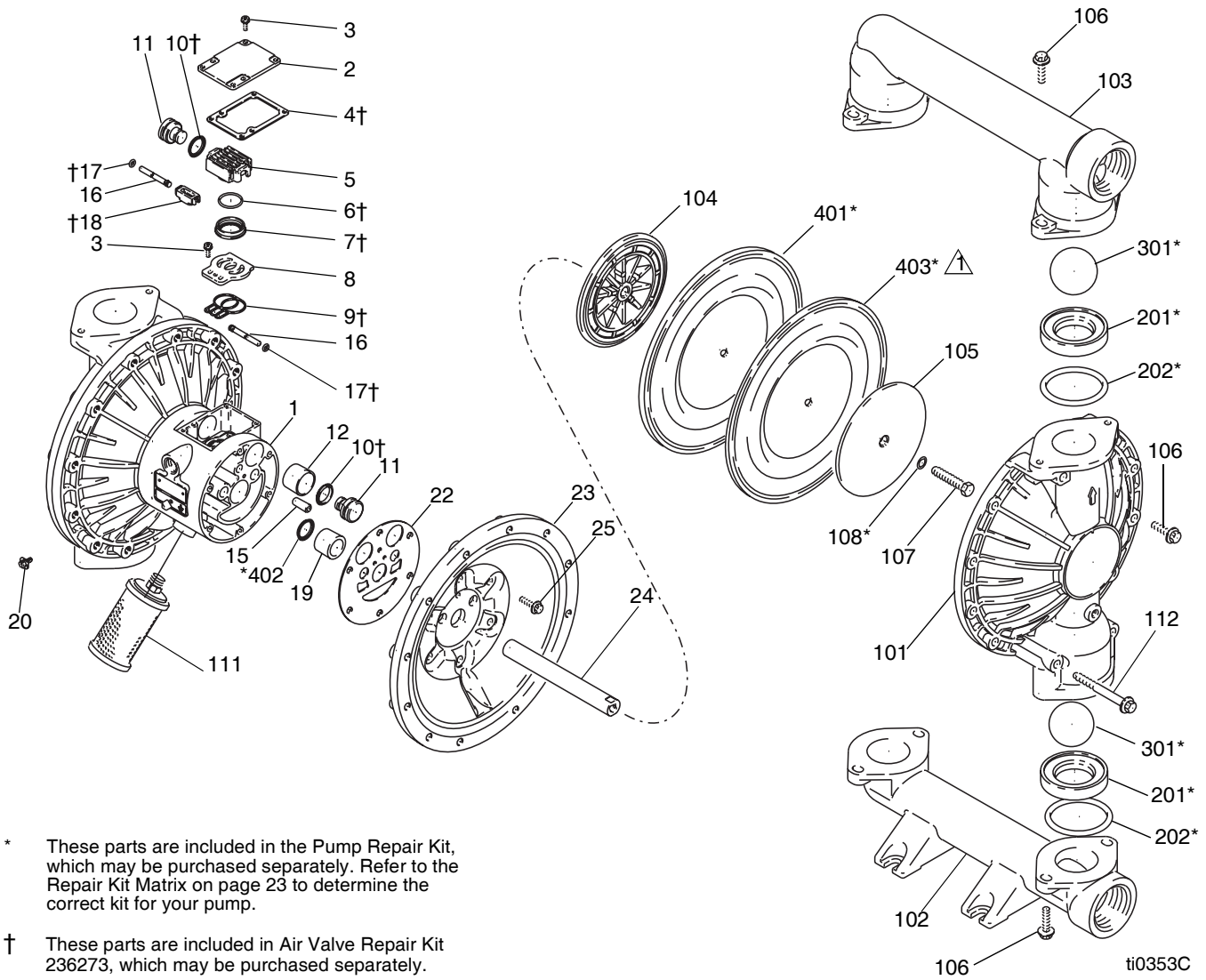

- * These parts are included in the Pump Repair Kit, which may be purchased separately. Refer to the Repair Kit Matrix on page 23 to determine the correct kit for your pump.
- † These parts are included in Air Valve Repair Kit 236273, which may be purchased separately.
- ▲ Replacement Danger and Warning labels, tags and cards are available at no cost.

ti0353C

Common Parts - All Pumps

Air Motor

Ref.	Part	Description	Qty.
1	188838	HOUSING, center	1
2	188854	COVER, air valve; alum.	1
3	116344	SCREW, mach, hex flange hd; M5x0.8; 12 mm (0.47 in.	9
4†	188618	GASKET, cover; foam	1
5	188855	CARRIAGE; aluminum	1
6†	108730	O-RING, nitrile	1
7†	188616	BLOCK, air valve; acetal	1
8	188615	PLATE, air valve; sst	1
9†	188617	SEAL, valve plate; buna-N	1
10†	112181	U-CUP; nitrile	2
11	188612	PISTON, actuator; acetal	2
12	188613	BEARING, piston; acetal	2
15	188611	BEARING, pin; acetal	2
16	188610	PIN, pilot; stainless steel	2
17†	157628	O-RING; buna-N	2
18†	188614	BLOCK, pilot; acetal	1
19	188609	BEARING, shaft; acetal	2
20	116343	SCREW, grounding	1
22	188603	GASKET, air cover; foam	2
23	189300	COVER, air; aluminum	2
24	189304	SHAFT, diaphragm; sst	1
25	115643	SCREW; M8x.25; 25 mm	12

Fluid Section

Ref.	Part	Description	Qty.
101	15A612	COVER, fluid; aluminum	2
102	192086	MANIFOLD, inlet; aluminum, BSPT	1
103	15A614	MANIFOLD, outlet; aluminum, BSPT	1
104	189298	PLATE, air side, aluminum	2
105	189820	PLATE, fluid side, carbon steel	2
106	115644	SCREW; M10 x 1.18; 30 mm	24
107	189410	BOLT; M12 x 1.75; 55 mm (2.17 in.); 316 stainless steel	2
108*	104319	O-RING; PTFE	2
110▲	16F991	LABEL, warning	1
111	102656	MUFFLER	1
112	115645	SCREW; M10 x 1.50; 90 mm (3.54 in.); carbon steel	8
113▲	15J300	TAG, warning, retorque	1

Seats, Balls, Diaphragms

Ref.	Part	Description	Qty.
201*	189290	SEAT; Santoprene	4
	189291	SEAT; Polypropylene	4
202*	112358	O-RING; PTFE	4
301*	112359	BALL; PTFE	4
	112361	BALL; Santoprene	4
401*	not sold	DIAPHRAGM, backup; separately neoprene (used with PTFE dia- phragms)	2
	189296	DIAPHRAGM, Santoprene	2
402*	112181	U-CUP, nitrile	2
403*	15K313	DIAPHRAGM, PTFE	2

† Included in Air Valve Repair Kit 236273.

‡ Included in Fluid Section Repair Kit DOFxxx.

▲ Replacement Danger and Warning labels, tags, and cards are available at no cost.

Fluid Section Repair Kits

Part Number	Configuration Number	Kit
TF24T072	TFG800ASP	D0F666
TF24T073	TFG800ATF	D0F911

Dimensions

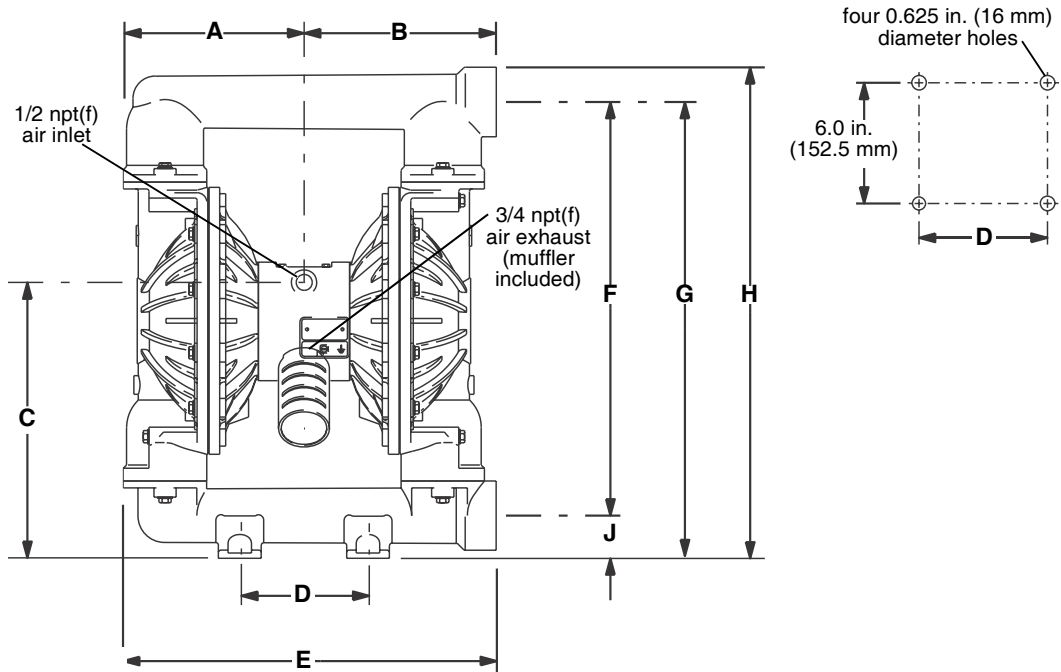

Ref	Dimension
A	8.39 in. (213.1 mm)
B	9.06 in. (230.1 mm)
C	12.3 in. (312.4 mm)
D	6.0 in. (152.4 mm)
E	17.45 in. (443.2 mm)
F	19.9 in. (505.5 mm)
G	21.9 in. (556.3 mm)
H	23.53 in. (597.7 mm)
J	2.0 in. (50.8 mm)
K	0.38 in. (9.7 mm)

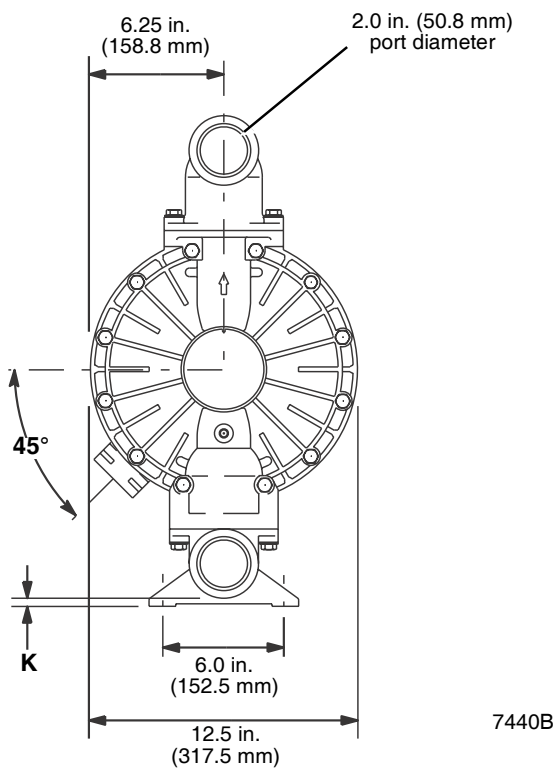

7440B

Performance Charts

Operating Air Pressure

- A**
120 psi (0.8 MPa, 8.0 bar)
- B**
100 psi (0.7 MPa, 7.0 bar)
- C**
70 psi (0.48 MPa, 4.8 bar)
- D**
40 psi (0.28 MPa, 2.8 bar)

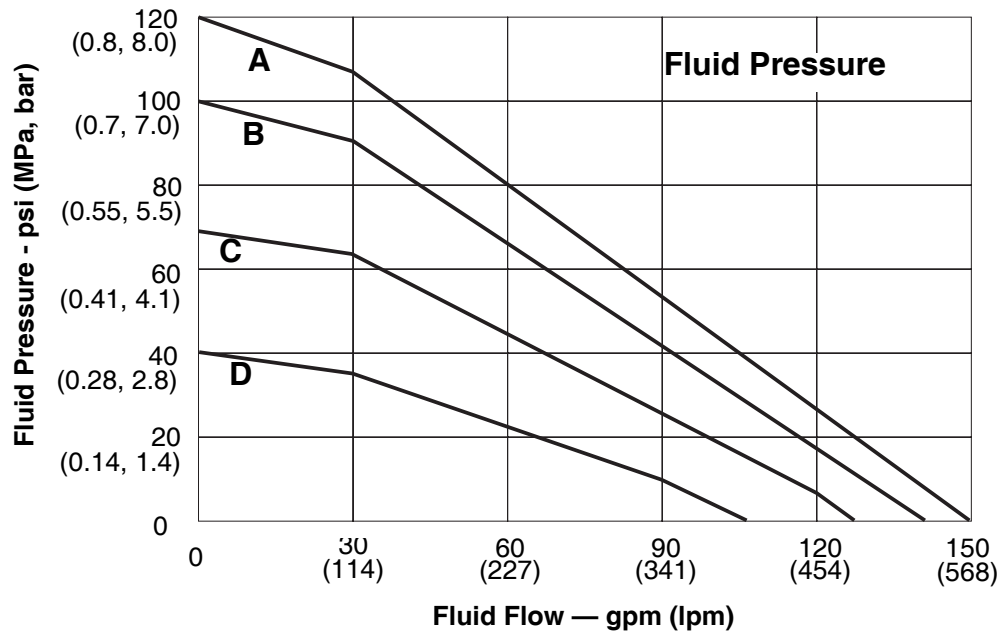

How to Read the Charts

1. Locate fluid flow rate along bottom of chart.
2. Follow vertical line up to intersection with selected operating air pressure curve.
3. Follow left to scale to read **fluid outlet pressure** (top chart) or **air consumption** (bottom chart).

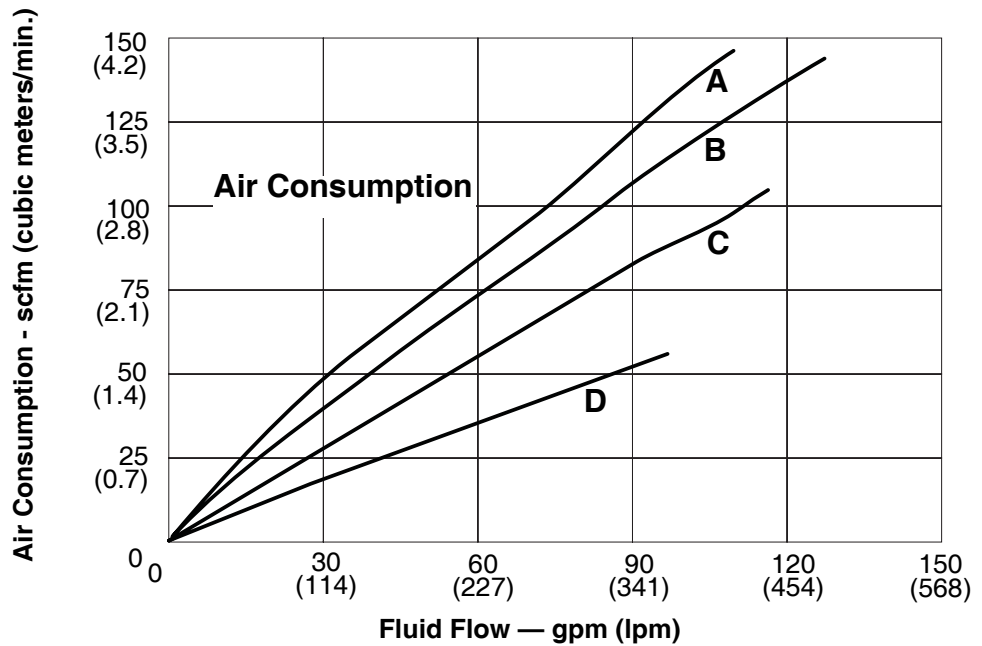

Technical Data

	US	Metric
Maximum fluid working pressure	120 psi	0.8 MPa, 8bar
Air pressure operating range	20 to 120 psi	0.14 to 0.8 MPa, 1.4 to 8 bar
Maximum air consumption	175 scfm	4.95 m ³ /minute
Air consumption at 70 psi (0.48 MPa, 4.8 bar) and 60 gallons (227 liters) per minute	60 scfm	1.69 m ³ /minute
Maximum free-flow delivery	150 gpm	568 l/min
Maximum pump speed	145 cpm	
Maximum size pumpable solids	1/4 in.	6.3 mm
Fluid flow per cycle	1.03 gallons	3.90 liters
Air inlet size	1/2 in. npt(f)	13 mm npt(f)
Fluid inlet and outlet size	2 in. bspt	51 mm bspt
Weight	58 lb	26.3 kg
Maximum Operating Temperature (Do not exceed the lowest maximum depending on the diaphragm, ball, and seat used in your pump.)		
Models with Santoprene diaphragms	150°F	66°C
Models with PTFE diaphragms	200°F	93.3°C
Maximum suction lift		
Dry	18 ft.	5.48 meters
Wet	18 ft.	5.48 meters
Noise Level*		
Sound power level	103 dBa	
Noise level at 70 psig (0.48 MPa, 4.8 bar) at 50 cycles per minute	85 dBa	
Maximum noise level at 100 psig (0.7 MPa, 7 bar) at 50 cycles per minute	90 dBa	
Materials of Construction		
Non-wetted external parts	aluminum, 302 and 316 stainless steel, polyester (labels)	
Wetted parts vary by model. See page 25.		
* Noise levels measured with the pump mounted on the floor, using Rubber Foot Kit 236452. Sound power measured per ISO Standard 9216.		

Techni-flow Standard Warranty

Techni-flow warrants all equipment referenced in this document which is manufactured by Techni-flow and bearing its name to be free from defects in material and workmanship on the date of sale to the original purchaser for use. With the exception of any special, extended, or limited warranty published by Techni-flow, Techni-flow will, for a period of twelve months from the date of sale, repair or replace any part of the equipment determined by Techni-flow to be defective. This warranty applies only when the equipment is installed, operated and maintained in accordance with Techni-flow's written recommendations.

This warranty does not cover, and Techni-flow shall not be liable for general wear and tear, or any malfunction, damage or wear caused by faulty installation, misapplication, abrasion, corrosion, inadequate or improper maintenance, negligence, accident, tampering, or substitution of non-Techni-flow component parts. Nor shall Techni-flow be liable for malfunction, damage or wear caused by the incompatibility of Techni-flow equipment with structures, accessories, equipment or materials not supplied by Techni-flow, or the improper design, manufacture, installation, operation or maintenance of structures, accessories, equipment or materials not supplied by Techni-flow.

This warranty is conditioned upon the prepaid return of the equipment claimed to be defective to an authorized Techni-flow distributor for verification of the claimed defect. If the claimed defect is verified, Techni-flow will repair or replace free of charge any defective parts. The equipment will be returned to the original purchaser transportation prepaid. If inspection of the equipment does not disclose any defect in material or workmanship, repairs will be made at a reasonable charge, which charges may include the costs of parts, labor, and transportation.

THIS WARRANTY IS EXCLUSIVE, AND IS IN LIEU OF ANY OTHER WARRANTIES, EXPRESS OR IMPLIED, INCLUDING BUT NOT LIMITED TO WARRANTY OF MERCHANTABILITY OR WARRANTY OF FITNESS FOR A PARTICULAR PURPOSE.

Techni-flow's sole obligation and buyer's sole remedy for any breach of warranty shall be as set forth above. The buyer agrees that no other remedy (including, but not limited to, incidental or consequential damages for lost profits, lost sales, injury to person or property, or any other incidental or consequential loss) shall be available. Any action for breach of warranty must be brought within two (2) years of the date of sale.

TECHNI-FLOW MAKES NO WARRANTY, AND DISCLAIMS ALL IMPLIED WARRANTIES OF MERCHANTABILITY AND FITNESS FOR A PARTICULAR PURPOSE, IN CONNECTION WITH ACCESSORIES, EQUIPMENT, MATERIALS OR COMPONENTS SOLD BUT NOT MANUFACTURED BY TECHNI-FLOW. These items sold, but not manufactured by Techni-flow (such as electric motors, switches, hose, etc.), are subject to the warranty, if any, of their manufacturer. Techni-flow will provide purchaser with reasonable assistance in making any claim for breach of these warranties.

In no event will Techni-flow be liable for indirect, incidental, special or consequential damages resulting from Techni-flow supplying equipment hereunder, or the furnishing, performance, or use of any products or other goods sold hereto, whether due to a breach of contract, breach of warranty, the negligence of Techni-flow, or otherwise.

*All written and visual data contained in this document reflects the latest product information available at the time of publication.
Techni-flow reserves the right to make changes at any time without notice.*

Original instructions. This manual contains English. MM 332527

Techni-flow • 82270 Montpezat de Quercy • FRANCE
<http://pompe-techni-flow.com>
Revision E, March 2015